

## Features

Compact, High-efficiency

Universal Input:  
90~132V AC / 180~264V AC (switch  
selectable)

Operating altitude: up to 5,000m

Operating temp: -30°C to +70°C

Low leakage current:  
<2mA @ 240V AC

Approved to CE, CQC, RoHS,  
REACH

## 10PLS-450-XX

450W Enclosed AC/DC Power Supply



The 10PLS-450-XX flat-panel power supply offers a 35mm ultra-thin profile, universal AC input, and natural convection cooling for efficient thermal performance. It supports operation from -30°C to +70°C and provides high isolation, reliable performance, and a compact lightweight design. Safety and EMC specifications align with international standards including EN IEC 62368-1 and GB 4943.1. Suitable applications include industrial control, energy storage, charging infrastructure, LED systems, security, telecommunications, and smart home equipment.

## Models

Model Number	Input Voltage (V)	Output Voltage (V DC)	Output Voltage Range (V DC)	Output Current (A)	Rated Power (W)	Efficiency (%)	Ripple & Noise(max.) (mVp-p)
10PLS-450-12	90~132V AC	12	11.4~13.2	47.5	450	90	200
10PLS-450-15	180~264V AC (select via switch)	15	14.26~16.5	30	450	90	200
10PLS-450-24		24	22.8~26.4	18.8	451.2	91	240
10PLS-450-36	255~370V DC (230V AC when switch is open)	36	34.2~39.6	12.5	450	92	360
10PLS-450-42		42	39.9~46.2	10.7	449.4	92	360
10PLS-450-48		48	45.6~52.8	9.4	451.2	92	360

Input Specifications	
Parameter	Specification
Rated input voltage	100~132V AC / 200~240V AC (switch selectable)
Input voltage range	90~132V AC / 180~264V AC (switch selectable)
Rated input frequency	50~60 Hz
Input frequency range	47~63 Hz
Input current	10A Typ. @ 115V AC, 6A Typ. @ 230V AC
Maximum surge current	Cold start, 30A type / 115V AC, 60A type / 230V AC
Leakage current	< 2mA @ 240V AC

Output Specifications	
Parameter	Specification
Output Connector	Screw terminal
Line Regulation	±0.5% (@115V AC & 230V AC input)
Load Regulation	±1% (@ 115V AC & 230V AC input)
Rise time	50ms Typ. @ 115V AC & 230V AC
Available machine time	1500ms Typ. @ 115V AC & 230V AC
Hold-up time	16ms Typ. @ 115V AC, 20ms Typ. @ 230V AC
Capacitive load startup (Max)	<b>12V:</b> 20,000 µF Max, <b>15V:</b> 10,000 µF Max, <b>24V:</b> 8,000 µF Max, <b>36V:</b> 6,000 µF Max, <b>42V:</b> 5,000 µF Max, <b>48V:</b> 4,000 µF Max

Environmental Characteristics		
Parameter	Condition	Specification
Ambient temperature	Operating	-30°C to +70°C (cold start at -40°C)
Ambient temperature	Storage	-40°C to +85°C
Power derating	Temperature	>50°C: Power rating reduction of 2% per °C <115V AC: Power rating reduction of 0.6% per V (80% load @ 90V AC)
Operating humidity	—	20 to 90% RH (no condensation)
Operating altitude	—	0 to 5,000m (0 to 16,400 ft)
Impact test	Non-operational	IEC 60068-2-27, half-sine wave: 50G for 11ms; 3 times in each direction, totalling 9 times
Impact test	Operational	IEC 60068-2-27, half-sine wave: 10G for 11ms; 3 times in each direction, totalling 9 times
Vibration test	Non-operational	IEC 60068-2-6, random: 5Hz~500 Hz (2.09G); 20 minutes in all X, Y & Z
Vibration test	Operational	IEC 60068-2-6, sine wave: 20Hz~500 Hz (5 GHz); 10 Minute: 1 cycle; all axes X, Y, and Z: 60 minutes each
Overvoltage category	—	II (compliant with EN 62477-1 OVC III standard for 5000-meter altitude elevation)

Protection	
Parameter	Specification
Overvoltage	<b>12V:</b> <13.8~18V, <b>15V:</b> <18.0~21.0, <b>24V:</b> 27.6_32.4V, <b>36V:</b> <41.4~48.6V, <b>42V:</b> <52~60V, <b>48V:</b> <55.2~64.8
Overload / Overcurrent	110~150% rated load current, hiccups mode, non-lockout (automatic recovery)
Over Temperature	Automatic recovery
Short Circuit	Hiccups mode, unlocked (automatically restored after fault resolution)
Electrical Shock	Connect PE*4 to achieve Class I

Reliability Requirements	
Parameter	Specification
MTBF	Telcordia SR-332: > 700,000hrs, Input: 230V AC, Output: 100% load, Temperature: 25°C
Expected lifespan	10 years for the electrolytic capacitor (230V AC, 50% load @ 40°C)

Regulatory Compliance	
Parameter	Specification
Safety Entry Low Voltage	Safety Entry Low Voltage — SELV
Approvals	CE, CQC, RoHS, REACH
Standards	EN IEC 62368-1 + A11, GB 4943.1
Isolation Voltage	Input~Output: 3750V AC
	Input~Ground: 2000V AC
	Output~Ground: 500V AC

EMC	
Parameter	Specification
EMC Standards	EN 55032 + A11 + A1, EN 55035 + A11, EN IEC 61000-3-2 + A1 + A2, EN 61000-3-3 + A1 + A2
Electrostatic Discharge	IEC 61000-4-2: Level 4 Criteria A1, Air discharge: 15kV: Contact discharge: 8kV
Radiated Immunity	IEC 61000-4-3: Level 3, Criteria A1, 80MHz~1GHz, 10V/m, 1kHz, 80% modulation
EFT/Burst	IEC 61000-4-4: Level 3, Criteria A1, ±2kV
Surge Immunity	IEC 61000-4-5: Level 4, Criteria A1, Common mode 4: ±4kV, Differential mode 5: ±2kV
Conducted Immunity	IEC 61000-4-6: Level 3, Criteria A1, 150kHz~80MHz, 10Vrms
Magnetic Field Immunity	IEC 61000-4-8: Level 4, Criteria A1, 30A/meter
Voltage Dips & Interruptions	IEC 61000-4-11: 0% sudden drop: 1 cycle, Criteria B2: 40% sudden drop 10 cycles, Criteria C3: 70% sudden drop 25 cycles

Product Details	
Parameter	Specification
Shell base	Aluminium
Outer cover of housing	SGCC
Size (L × W × H)	225 x 124 x 35mm
Weight	0.93kg
Pilot lamp	Green LED (DC OK)
Cooling method	Natural convection
Wire	AWG 18–12 users shall calculate and select the appropriate wire specifications (type/quantity/diameter) based on the actual output current. The torque applied to terminal blocks/connectors must not exceed 8kN·cm (6.94lb·in). The wire pull length shall not exceed 0.275inch or 7mm.
Noise	Sound Pressure Level (SPL) < 45dBA

Block Diagram

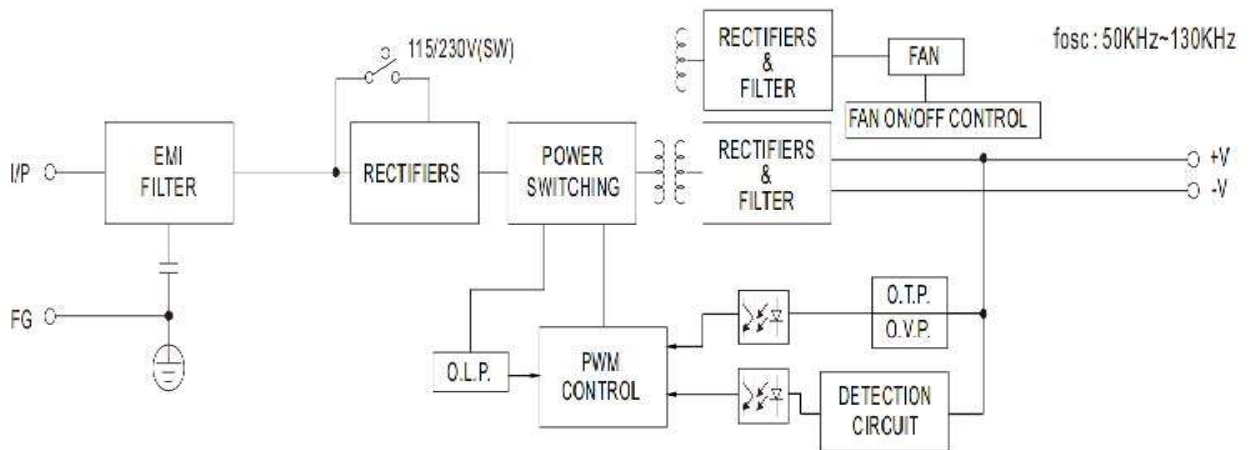

Power Supply Component Description

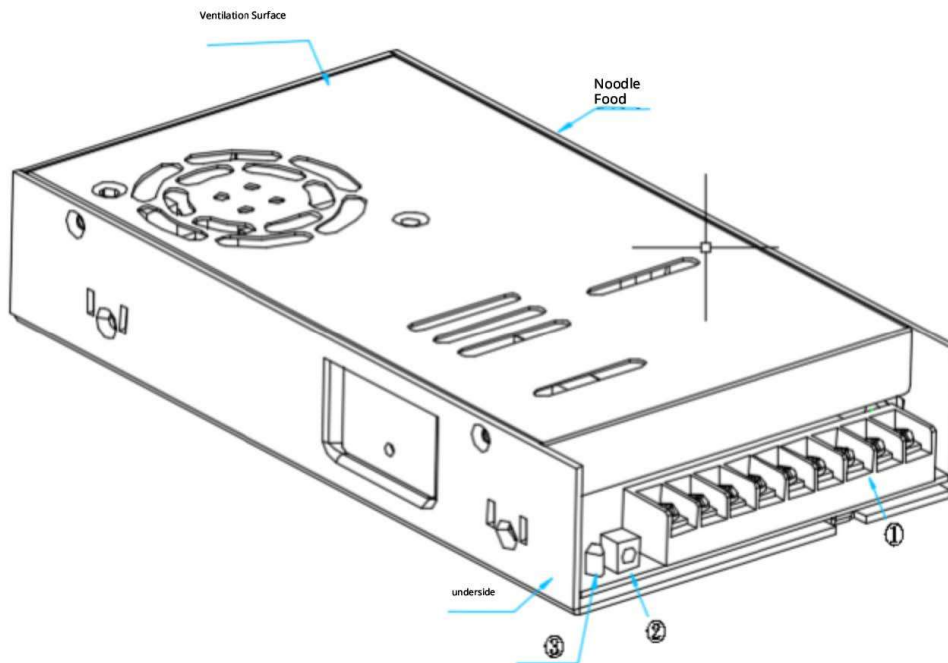

- 1) Input and Output Terminal Board
- 2) DC voltage adjustment potentiometer
- 3) DC OK LED indicator light (green)

Power Supply Component Description

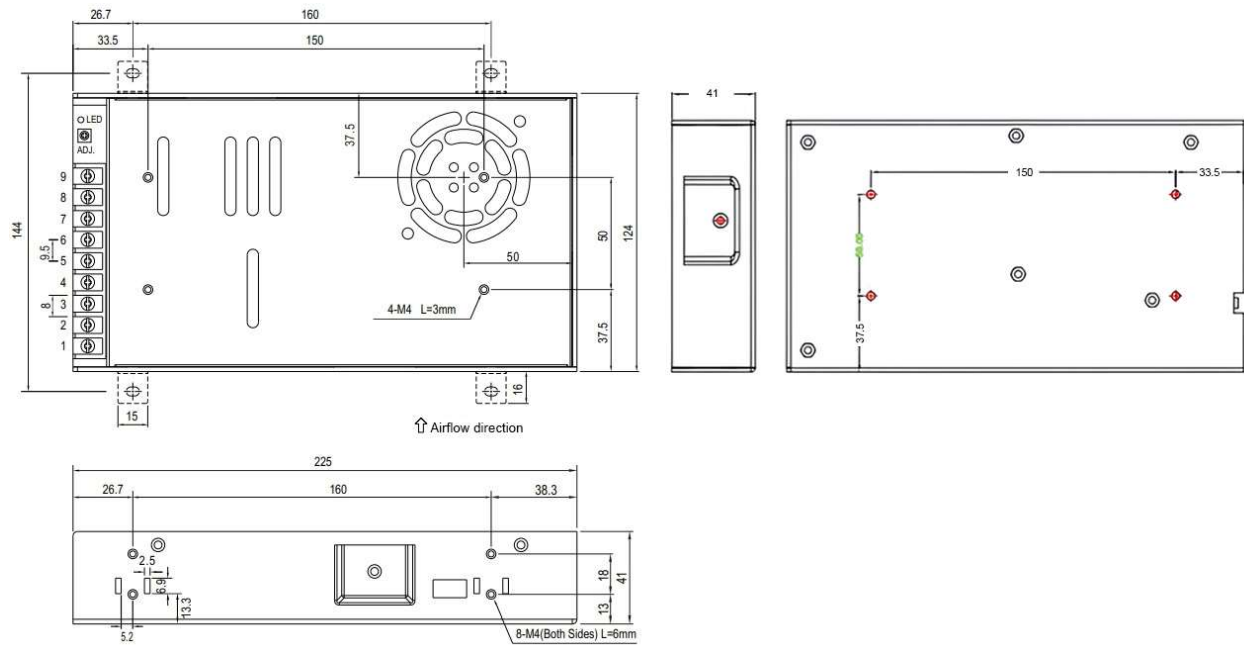

Unless otherwise specified, the dimensional tolerance is  $\pm 0.5$ .

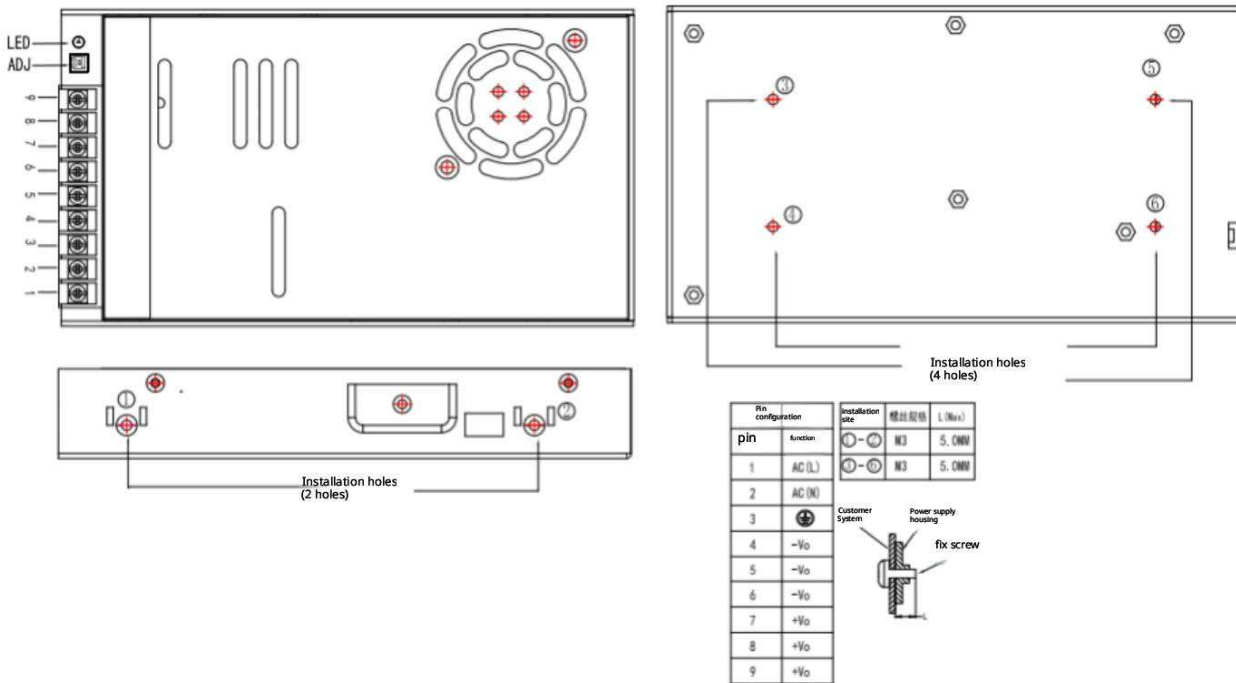

Unless otherwise noted, all parameters are based on an 25°C ambient temperature, 230V AC input, and rated output load

Engineering Data

The output load derating corresponds to the ambient temperature.

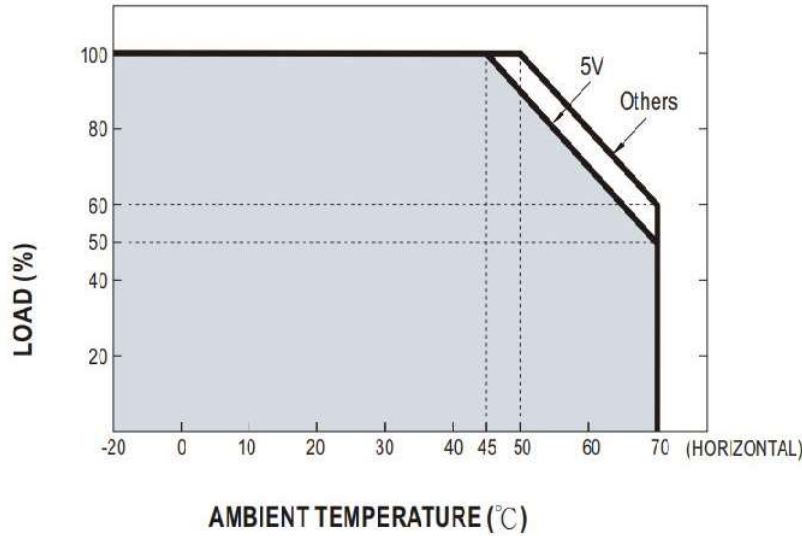

**Figure 1) Horizontal Installation Derating**  
 Power rating decreases by 2% per °C above 50°C

1. If the power supply is continuously operated outside the rated power curve, it may lead to component degradation or damage, as shown in Figures 1 and 2.
2. When the ambient temperature is below 30 °C, the PSU may enter a hiccupping state upon startup at for a duration ≤5 seconds.
3. When the ambient temperature exceeds 50°C, the power supply will activate overtemperature protection if the output power is not reduced. Once activated, the power supply remains locked until the ambient temperature decreases or the load returns to normal operating conditions. Release or reset input AC voltage to restart.
4. For proper functioning, the power supply must maintain a safe distance from other equipment during operation, as specified in the Safety Guidelines section.
5. Note: Depending on the ambient temperature and power output load, the power supply may overheat.

The output load derating corresponds to the input voltage.

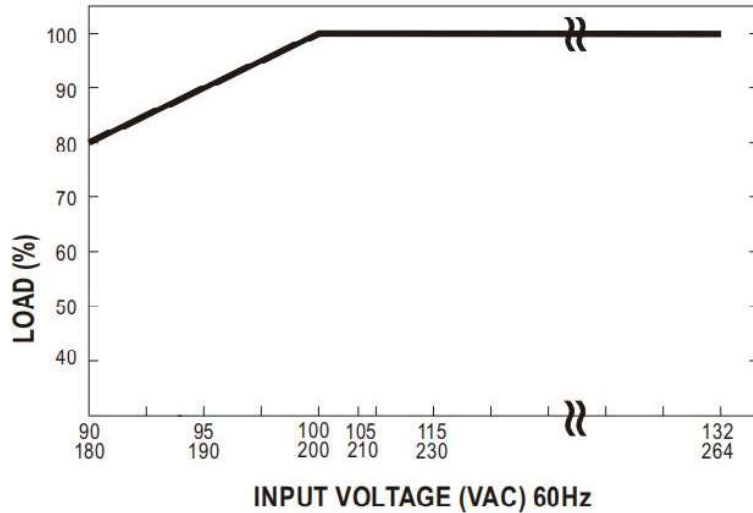

**Figure 2) AC Input Voltage Derating**  
 <115 Vac Power reduction: 0.6% / V

There is no output power degradation for input.  
 Voltages ranging from 115V AC~264V AC

**Assembling & Installation**

Power supply mounting holes on the installation surface. The below diagram shows the locations of the mounting holes for the power supply on a metal surface.

Install at least two holes using M4 screws, each no shorter than 5mm (0.20 inch) in length.

‡ This surface belongs to the customer terminal system or panel, with the power supply installed on it.

∅ Terminal Station

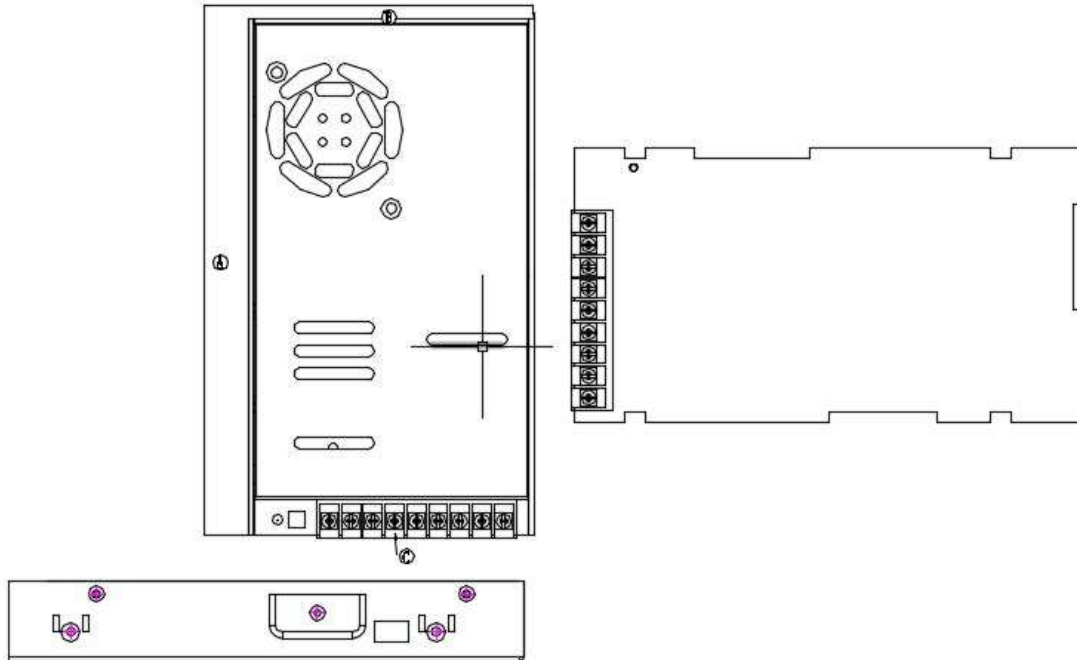

\*If the power supply needs to be installed in a different orientation, please contact Ideal for specific installation instructions.

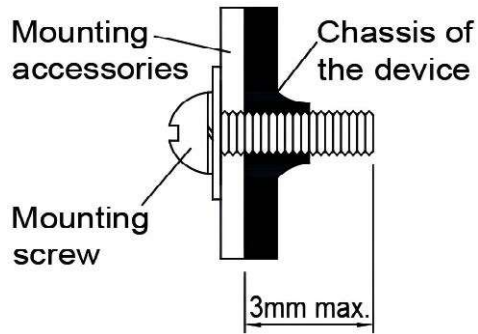

Unless otherwise noted, all parameters are based on an 25°C ambient temperature, 230VAC input, and rated output load

**Installation Instructions:**

Only M4 screws with a diameter  $\leq 3\text{mm}$  (0.20inch) are permitted for installation through base drilling to ensure secure fastening of screws to internal components.

Recommended installation tightening torque:  
4~7Kgf.cm (3.47~6.08lbf.in)

1. If you use the power supply in a non-recommended installation direction, please contact Ideal Power for consultation.
2. Ensure adequate convective cooling. When the power supply is in operation, all external components must maintain a safety distance of  $\geq 50\text{mm}$  (1.97inch) from the power supply ventilation surface.
3. It is not recommended to install power supplies on surfaces with low thermal conductivity coefficients, such as plastics.
4. Note: The power supply enclosure may overheat depending on ambient temperature and power load. Avoid contact during operation or immediately after shutdown to prevent burns!
5. Do not touch the terminal block under power supply conditions to avoid electric shock.
6. During installation, it is imperative to ensure that no external metals, objects, or conductors enter the power supply to prevent electric shocks, safety hazards, fires, or machine operational failures.
7. The power supply must be installed on a grounded metal surface using metal screws. It is strongly recommended to connect the grounding terminals of the power supply terminal block to the earth.

**Function**

**Figure 1) Diagram of Turn-on Time, Rise Time, and Hold Time**

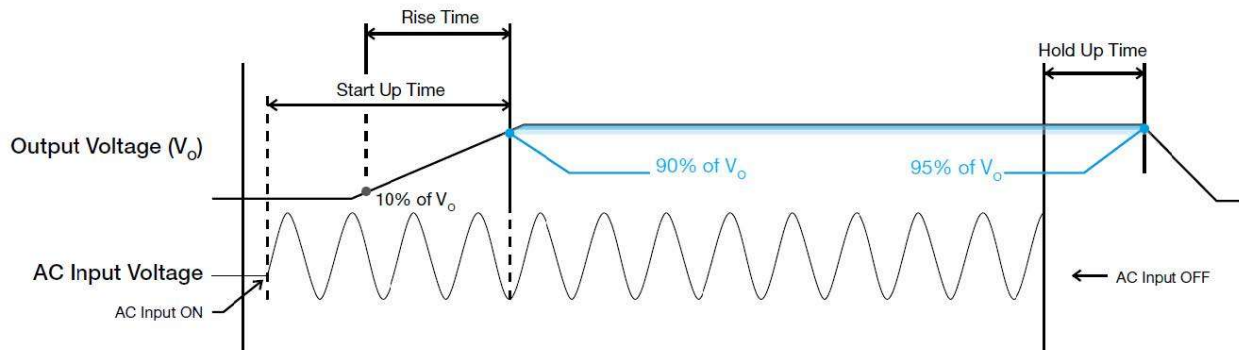
**Available Machine Time:**

The time required for the output voltage to rise to 90% of the rated value after the input voltage is applied.

**Rise Time:**

The time required for the output voltage to change from 10% to 90% of its final steady-state value.

**Retention Time:**

The time interval between the interruption of the AC input voltage and the output voltage dropping below 95% of its final steady-state value.

Function

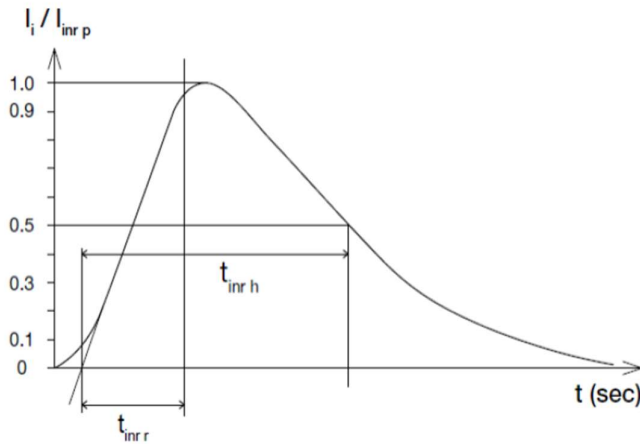

**Surge Current**

Surge current refers to the instantaneous peak current generated upon the activation of the input voltage. Under AC input voltage, the maximum surge current occurs during the upper half-cycle of the AC voltage, with its peak value declining exponentially in subsequent cycles.

**Overload and overcurrent protection (automatic recovery)**

When the output current exceeds 110% of  $I_o$  (maximum load), the power supply's overload (OLP) and overcurrent (OCP) protection mechanisms are triggered. In this scenario,  $V_o$  begins to decrease; once the power supply reaches its maximum power limit, the protection is activated, and the power supply enters "hiccup mode" (automatic recovery). Once the OLP or OCP failure is resolved and  $I_o$  returns to the normal range, power can be restored.

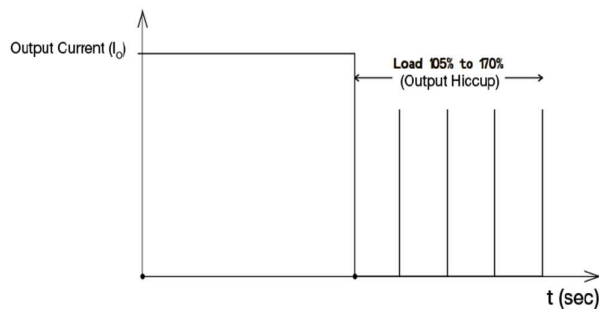

**Short-circuit protection (automatic recovery)**

The OLP/OCP power output function also provides short-circuit protection. During a short circuit, the output current operates in a "hiccup mode," and the power supply returns to normal operation once the short circuit is resolved.

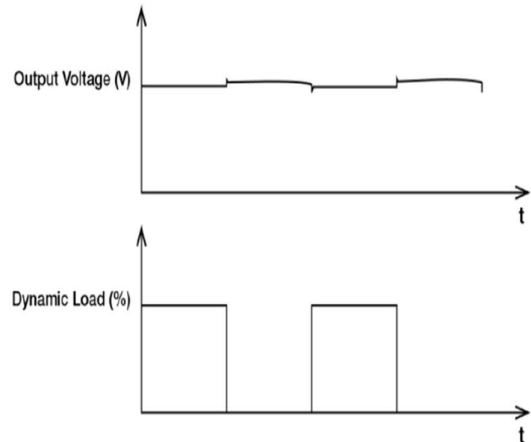

**Dynamic Response**

When the dynamic load varies dynamically from 10% to 100%, the power supply output voltage maintains a stable regulation rate of  $\pm 10\%$ .

**Overvoltage protection (automatic recovery)**

When internal feedback fails, the power overvoltage circuit is triggered, and the output voltage must not exceed the range specified in the "Protection" section. The power supply resumes normal operation after protection and fault resolution.

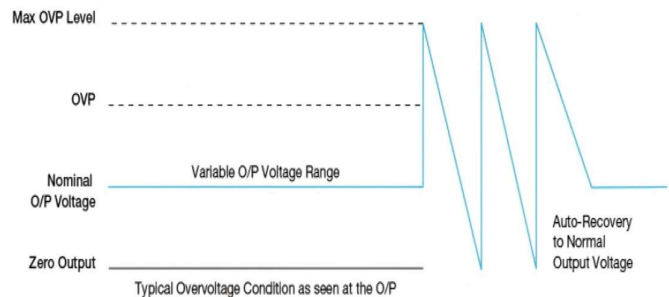

**Overtemperature protection (automatic recovery)**

As described in the Load Derating section, the power supply incorporates overtemperature protection (OTP) functionality. If the operating temperature exceeds the specified limits under 100% load conditions, the OTP circuit is triggered, and the output voltage enters a hiccup mode until the temperature returns to the normal operating range recommended by the derating chart.